



# OD2000-2452T15

## OD2000

DISPLACEMENT MEASUREMENT SENSORS

**SICK**  
Sensor Intelligence.



### Ordering information

Type	Part no.
OD2000-2452T15	6074383

Other models and accessories → [www.sick.com/OD2000](http://www.sick.com/OD2000)



### Detailed technical data

#### Features

<b>Measuring range</b>	70 mm ... 420 mm <sup>1)</sup>
<b>Target</b>	Natural objects
<b>Repeatability</b>	10 µm <sup>2) 3) 4)</sup>
<b>Linearity</b>	± 350 µm <sup>2) 4) 5)</sup>
<b>Response time</b>	≥ 0.533 ms <sup>6)</sup>
<b>Output time</b>	≥ 0.1333 ms
<b>Light source</b>	Laser, red visible red light
<b>Type of light</b>	Visible red light
<b>Laser class</b>	2 (IEC 60825-1:2014, EN 60825-1:2014) <sup>7)</sup>
<b>Typ. light spot size (distance)</b>	Ø 500 µm (245 mm)
<b>Additional function</b>	Adjustable average value or media filter Switching mode: Distance to Object (DtO) / switching window / object between sensor and background (ObSB) Teach-in of digital output Invertable digital output Teach-in of analog output Invertable analog output Switchable analog output (mA / V) Multifunctional input: sender off/hold functions/deactivated Switch-off display

<sup>1)</sup> 6 % ... 90 % remission; at default settings.

<sup>2)</sup> Measurement on 60 % remission (ceramic, white).

<sup>3)</sup> Average value setting: 512, median: 31, measuring frequency: 5 kHz, in the middle of the measuring range, for static measurement.

<sup>4)</sup> At T = +25 °C, under constant general conditions.

<sup>5)</sup> Observe min. warm-up time of 30 minutes.

<sup>6)</sup> Dependent on the set average or sensitivity.

<sup>7)</sup> Visible, wavelength: 655 nm, max. average power: 1 mW, max. pulse power: 1 mW, max. pulse duration: 5 ms.

	Lock user interface Display can be rotated by 180° Alarm function Edge height jump Time functions (ON/OFF delay, 1 shot) region of interest
<b>Safety-related parameters</b>	
	MTTF <sub>D</sub> 107 years
	DC <sub>avg</sub> 0%

- 1) 6 % ... 90 % remission; at default settings.
- 2) Measurement on 60 % remission (ceramic, white).
- 3) Average value setting: 512, median: 31, measuring frequency: 5 kHz, in the middle of the measuring range, for static measurement.
- 4) At T = +25 °C, under constant general conditions.
- 5) Observe min. warm-up time of 30 minutes.
- 6) Dependent on the set average or sensitivity.
- 7) Visible, wavelength: 655 nm, max. average power: 1 mW, max. pulse power: 1 mW, max. pulse duration: 5 ms.

## Interfaces

<b>IO-Link</b>	✓, IO-Link V1.1
Function	Process data, parameterization, diagnosis, data storage
Data transmission rate	230,4 kbit/s (COM3), Process data length 6 bytes, min. cycle time 0.7 ms
<b>Digital input</b>	In <sub>1</sub> Can be used as sender off, trigger for hold functions, or deactivated
<b>Digital output</b>	
Number	2 <sup>1)</sup>
Type	PNP/NPN, selectable
<b>Analog output</b>	
Number	1
Type	Current output / voltage output
Function	Selectable
Current	4 mA ... 20 mA, ≤ 300 Ω
Voltage	0 V ... 10 V, > 10,000 Ω
Resolution	16 bit

<sup>1)</sup> PNP/PP: HIGH = UV > 13.5 V/LOW = UV < 8 V; NPN: HIGH = UV < 8 V/LOW = UV > 13.5 V.

## Electronics

<b>Supply voltage U<sub>B</sub></b>	DC 18 V ... 24 V, ± 10%, including residual ripple <sup>1)</sup>
<b>Power consumption</b>	1.5 W, At 24 V DC <sup>2)</sup>
<b>Warm-up time</b>	< 30 min
<b>Indication</b>	OLED display, status LEDs
<b>Enclosure rating</b>	IP67
<b>Protection class</b>	III (EN 50178)
<b>Electrical safety</b>	IEC 61010-1 AMD 1:2016-12

- 1) Limit values, reverse-polarity protected.
- 2) Without load, at +20 °C.

## Mechanics

<b>Dimensions (W x H x D)</b>	27 mm x 60 mm x 50 mm
-------------------------------	-----------------------

<b>Control elements</b>	4 buttons
<b>Housing material</b>	Plastic (PBT)
<b>Window material</b>	Plastic (PMMA)
<b>Weight</b>	90 g
<b>Connection type</b>	Cable with male connector, M12, 5-pin, A-coded, 30 cm

### Ambient data

<b>Ambient temperature, operation</b>	-10 °C ... +50 °C, Operating temperature at $V_S = 24\text{ V}$
<b>Ambient temperature, storage</b>	-20 °C ... +60 °C
<b>Relative air humidity (non-condensing)</b>	35 % ... 85 %
<b>Temperature drift</b>	210 $\mu\text{m/K}$
<b>Typ. Ambient light immunity</b>	Artificial light: $\leq 3,000\text{ lx}$ <sup>1)</sup> Sunlight: $\leq 10,000\text{ lx}$
<b>Vibration resistance</b>	EN 60068-2-6, EN 60068-2-64
<b>Shock resistance</b>	EN 60068-2-27

<sup>1)</sup> With constant object movement in the measuring range.

### Classifications

<b>ECLASS 5.0</b>	27270801
<b>ECLASS 5.1.4</b>	27270801
<b>ECLASS 6.0</b>	27270801
<b>ECLASS 6.2</b>	27270801
<b>ECLASS 7.0</b>	27270801
<b>ECLASS 8.0</b>	27270801
<b>ECLASS 8.1</b>	27270801
<b>ECLASS 9.0</b>	27270801
<b>ECLASS 10.0</b>	27270801
<b>ECLASS 11.0</b>	27270801
<b>ECLASS 12.0</b>	27270916
<b>ETIM 5.0</b>	EC001825
<b>ETIM 6.0</b>	EC001825
<b>ETIM 7.0</b>	EC001825
<b>ETIM 8.0</b>	EC001825
<b>UNSPSC 16.0901</b>	41111613

**Dimensional drawing** (Dimensions in mm (inch))

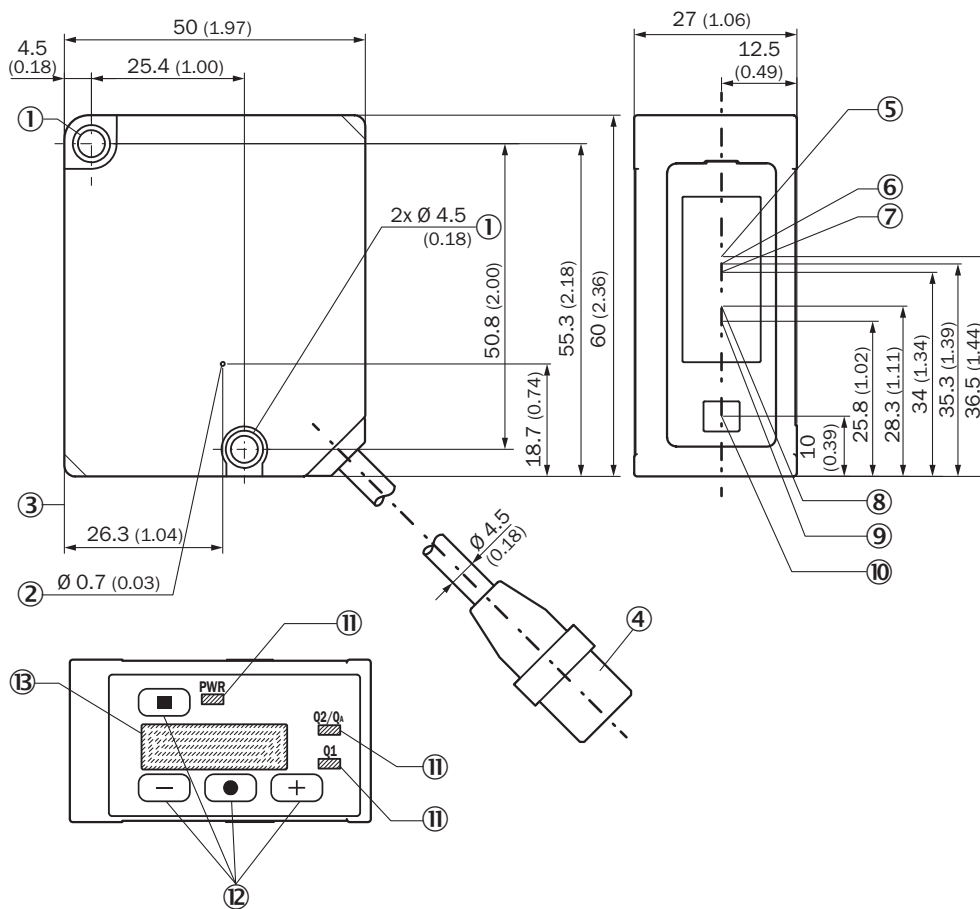

Structure and device dimensions, unit: mm (inch), decimal separator: period

- ① M4 fixing holes
- ② Ventilation opening (do not cover)
- ③ Device zero point (distance = 0 mm)
- ④ Device cable (length: 300 mm) with male connector, M12, 5-pin, A-coded
- ⑤ Center of optical axis, receiver (device type OD2000-350, OD2000-700)
- ⑥ Center of optical axis, receiver (device type OD2000-245)
- ⑦ Center of optical axis, receiver (device type OD2000-130)
- ⑧ Center of optical axis, receiver (device type OD2000-050)
- ⑨ Center of optical axis, receiver (device type OD2000-030)
- ⑩ Center of optical axis, sender
- ⑪ Status LEDs
- ⑫ Control elements
- ⑬ Display

Interference diagram

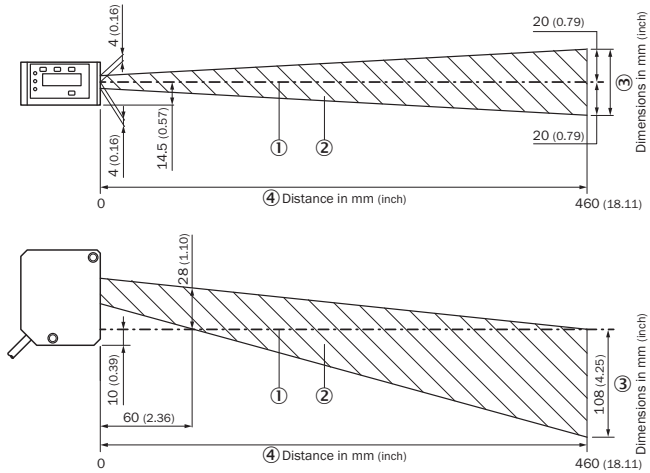

- ① Optical axis sender and receiver
- ② Interference diagram
- ③ Dimensions in mm (inch)
- ④ Distance in mm

Connection diagram

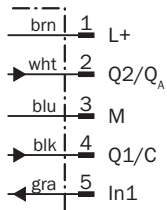

- ① Brown
- ② White
- ③ Blue
- ④ Black
- ⑤ Gray

Light spot size

Typical light spot size OD2000-245xxx

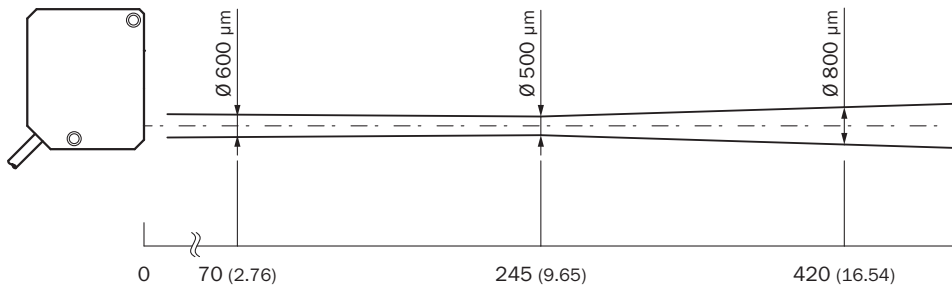

Unit: mm (inch), decimal separator: period

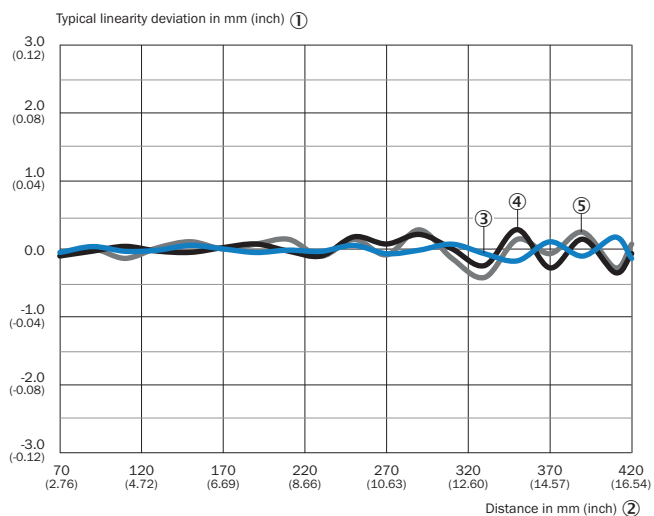

## Linearity



- ① Typical linearity deviation in mm (inch)
- ② Distance in mm (inch)
- ③ White 60% remission factor
- ④ Black 9.5% remission factor
- ⑤ Stainless steel

## Recommended accessories

Other models and accessories → [www.sick.com/OD2000](http://www.sick.com/OD2000)

	Brief description	Type	Part no.
<b>Connection modules</b>			
	<ul style="list-style-type: none"> <li><b>Description:</b> IO-Link V1.1 Class A port, USB2.0 port, optional external power supply 24V / 1A</li> <li><b>Logic editor:</b> no</li> </ul>	IOLA2US-01101 (SiLink2 Master)	1061790
<b>Mounting brackets and plates</b>			
	<ul style="list-style-type: none"> <li><b>Description:</b> Stainless-steel mounting bracket</li> <li><b>Material:</b> Stainless steel</li> <li><b>Details:</b> Stainless steel</li> </ul>	BEF-WN-OD2000	4112929
	<ul style="list-style-type: none"> <li><b>Connection type head A:</b> Female connector, M12, 5-pin, straight, A-coded</li> <li><b>Connection type head B:</b> Flying leads</li> <li><b>Signal type:</b> Sensor/actuator cable</li> <li><b>Cable:</b> 2 m, 5-wire, PVC</li> <li><b>Description:</b> Sensor/actuator cable, unshielded</li> <li><b>Application:</b> Zones with chemicals, Uncontaminated zones</li> </ul>	YF2A15-020VB5XLEAX	2096239

## SICK AT A GLANCE

SICK is one of the leading manufacturers of intelligent sensors and sensor solutions for industrial applications. A unique range of products and services creates the perfect basis for controlling processes securely and efficiently, protecting individuals from accidents and preventing damage to the environment.

We have extensive experience in a wide range of industries and understand their processes and requirements. With intelligent sensors, we can deliver exactly what our customers need. In application centers in Europe, Asia and North America, system solutions are tested and optimized in accordance with customer specifications. All this makes us a reliable supplier and development partner.

Comprehensive services complete our offering: SICK LifeTime Services provide support throughout the machine life cycle and ensure safety and productivity.

For us, that is “Sensor Intelligence.”

## WORLDWIDE PRESENCE:

Contacts and other locations –[www.sick.com](http://www.sick.com)